

Integrated Freewheels FXM

for bolting to the face
with sprag lift-off X



Features

Integrated Freewheels FXM are sprag free-wheels without bearing support and with sprag lift-off X.

The sprag lift-off X ensures a wear-free freewheeling operation when the inner ring rotates at high speed.

The freewheels FXM are used as:

- ▶ Backstops
- ▶ Overrunning Clutches

for applications with high speed freewheeling operation and when used as an overrunning clutch with low speed driving operation.

Nominal torques up to 364 000 Nm.

Bores up to 320 mm. Many standard bores are available.

Sprag lift-off X

Integrated Freewheels FXM are equipped with sprag lift-off X. The sprag lift-off X is used for backstops and overrunning clutches, provided that in freewheeling operation the inner ring is rotating at high speed and providing with overrunning clutches that the driving operation is conducted at low speed. In freewheeling operation, the centrifugal force F_C causes the sprag to lift off from the outer track. In this operating state, the freewheel works wear-free, i.e. with unlimited service life.

Figure 60-2 shows a freewheel with sprag lift-off X in freewheeling operation. The sprags, which are supported in a cage connected with the inner ring, rotate with the inner ring. The centrifugal force F_C that is applied in the center of gravity S of the sprag turns the sprag anti-clockwise and rests against the support ring of the cage. This results in the gap a between the sprag and the outer track; the freewheel works without contact. If the inner ring speed decreases to such an extent that the effect of the cen-

trifugal force on the sprag is less than that of the spring force F_F , the sprag again rests on the outer ring and the freewheel is ready to lock (figure 60-3). If used as an overrunning clutch, the driving speed must not exceed 40% of the lift-off speed.

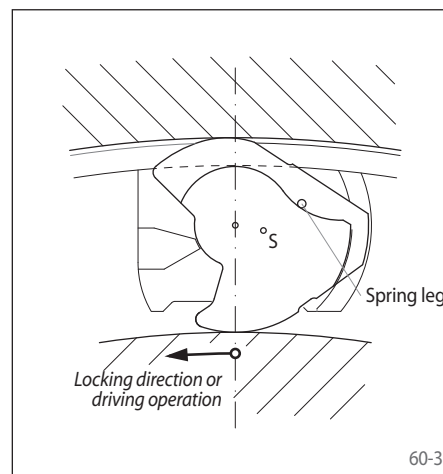
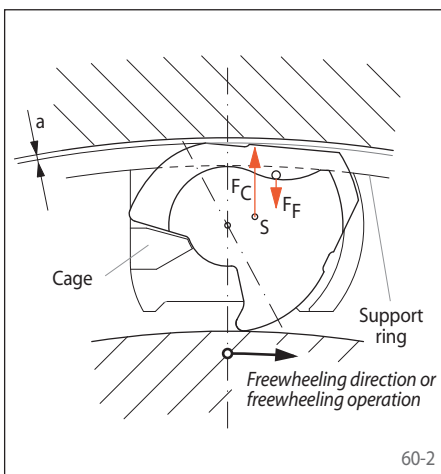

Integrated Freewheels FXM

for bolting to the face
with sprag lift-off X

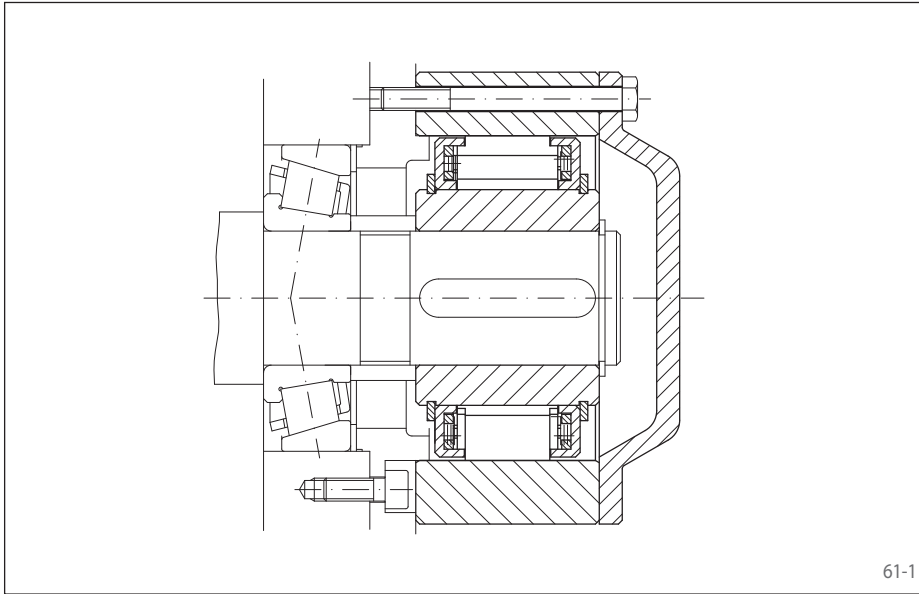

61-1

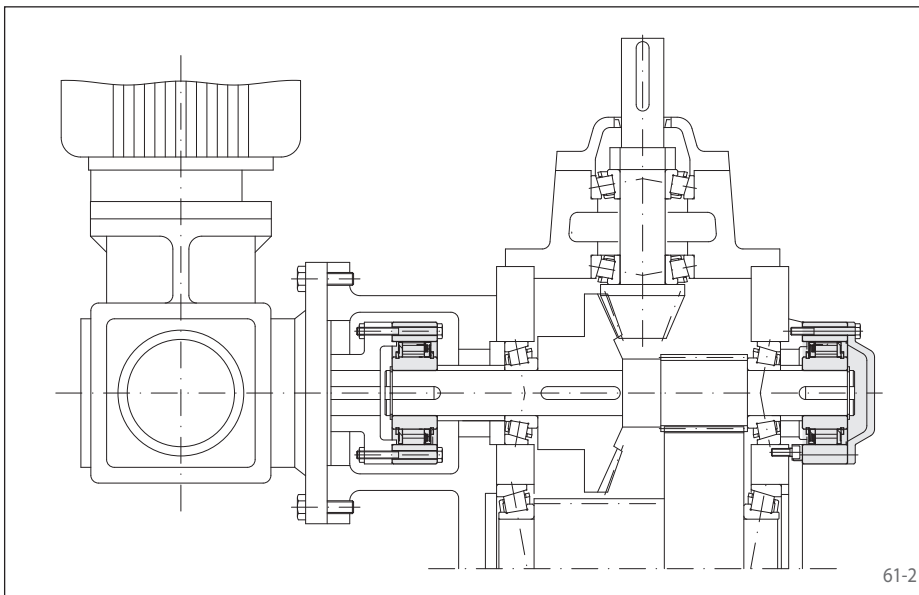

61-2

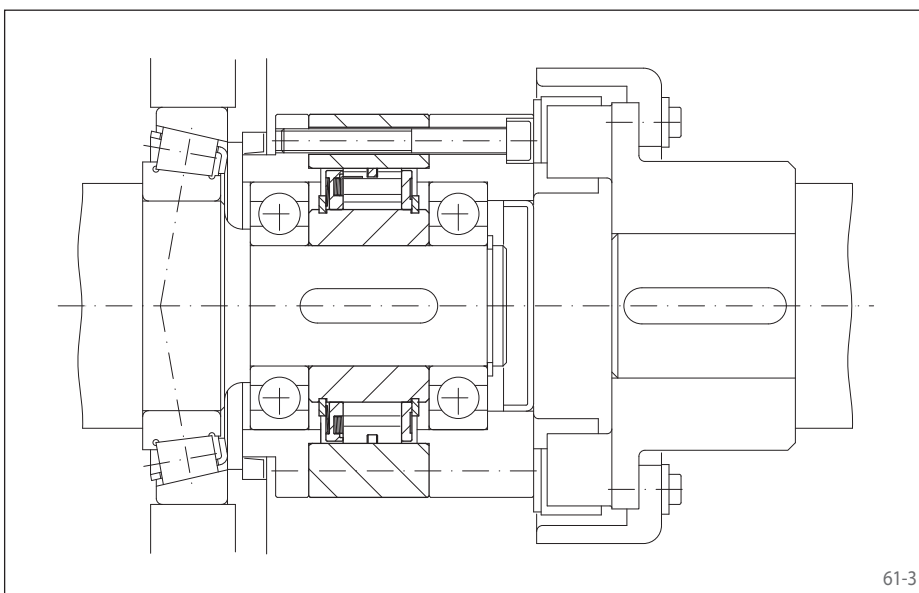

61-3

Application example

Integrated Freewheel FXM 170 - 63 SX with end cover as backstop fitted to the end of the first intermediate shaft of a spur gearbox in the drive of an inclined conveyor belt. In the case of a motor stop, the conveyor belt must be held securely so that the conveyor goods do not pull the belt backwards and possibly cause serious damage. Due to the high shaft speeds in normal operation (freewheeling operation), the sprag lift-off X ensures a contactless and hence wear-free continuous operation.

Application example

Two Integrated Freewheels FXM 120 - 50 SX in the gearbox unit of a vertical bucket conveyor. Alongside the main drive, the bucket conveyor has a creep drive, which can be moved at a low speed if maintenance work needs to be carried out. The freewheel arranged between the creep drive and the main drive works as an overrunning clutch. When the creep drive operates, the freewheel is in driving operation. In normal operation, when driving via the main drive, the inner ring of the freewheel overruns at high speed and automatically disengages the creep drive. The second freewheel that is arranged on the end of the first intermediate shaft of the main gearbox, works as a backstop and prevents the bucket conveyor from running back when the unit is at a standstill.

Application example

Integrated Freewheel FXM 76-25 DX as an overrunning clutch between the creep drive and the main drive of a cement mixer. When the creep drive operates, the outer ring is driven by the shaft coupling. The freewheel works in driving operation and drives the unit at a low speed via the main gearbox. In normal operation (freewheeling operation), the inner ring overruns at high speed and the creep drive is automatically disengaged. With the high shaft speed, the type sprag lift-off X is used; the sprags work in freewheeling operation without contact and hence are wear-free. The arrangement of the seals between the freewheel and the main gearbox is advantageous. In freewheeling operation, this is at a standstill and hence generates no additional friction-related temperature rise.

Integrated Freewheels FXM ... DX and FXM ... SX

for bolting to the face
with sprag lift-off X

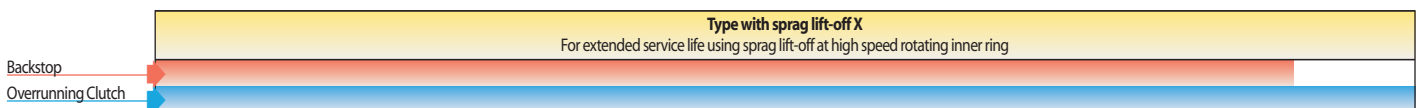
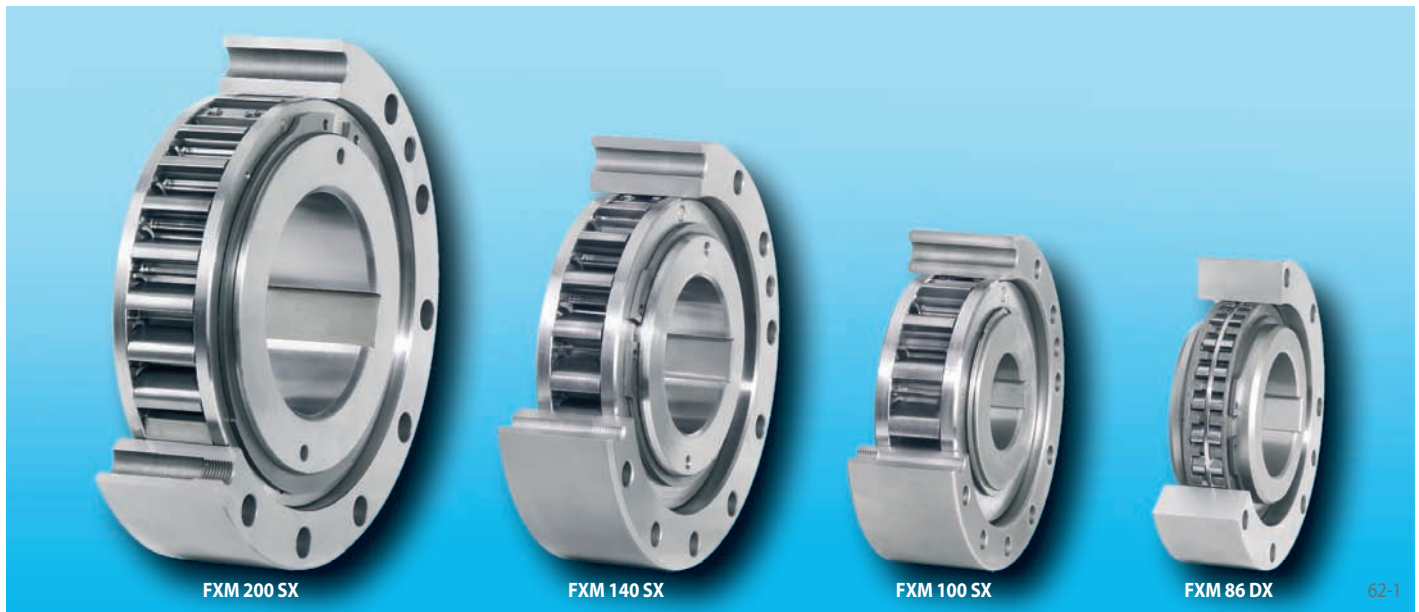

Freewheel Size	Type	Theoretical nominal torque Nm	Nominal torque at existing run out (T.I.R.)						Sprag lift-off at inner ring speed min ⁻¹	Max. speed	
			0,1 A Nm	0,2 A Nm	0,3 A Nm	0,4 A Nm	0,5 A Nm	Inner ring freewheels/overruns min ⁻¹		Outer ring drives min ⁻¹	
FXM 31 - 17	DX	100	100	95				890	5000	356	
FXM 38 - 17	DX	150	140	130				860	5000	344	
FXM 46 - 25	DX	390	380	350				820	5000	328	
FXM 51 - 25	DX	480	470	420				750	5000	300	
FXM 56 - 25	DX	580	570	490				730	5000	292	
FXM 61 - 19	DX	420	410	370				750	5000	300	
FXM 66 - 25	DX	800	780	700				700	5000	280	
FXM 76 - 25	DX	1050	1040	890				670	5000	268	
FXM 86 - 25	DX	1350	1300	1030				630	5000	252	
FXM 101 - 25	DX	1700	1600	1400				610	5000	244	
FXM 85 - 40	SX	1900	1900	1800	1800	1700	1600	430	6000	172	
FXM 100 - 40	SX	2700	2600	2500	2400	2200	2000	400	4500	160	
FXM 120 - 50	SX	6500	6300	5800	4800	4400	3600	320	4000	128	
FXM 140 - 50	SX	8700	8500	7900	6700	5500	5400	320	3000	128	
FXM 170 - 63	SX	20000	19000	16000	14000	13000	12000	250	2700	100	
FXM 200 - 63	SX	26000	23000	20500	17500	15500	14000	240	2100	96	

The maximum transmissible torque is 2 times the specified nominal torque. See page 14 for determination of selection torque.
The theoretical nominal torque applies only for ideal concentricity between the inner and outer ring. In practice, the concentricity is affected by the bearing play and centering errors of the neighbouring parts. Then the nominal torques specified in the table apply, whilst taking into consideration the existing run out (T.I.R.).
Higher speeds upon request.

Mounting

Integrated Freewheels FXM are without bearing support. Concentric alignment of inner and outer ring must be provided by the customer. The permissible run out (T.I.R.) must be observed.

The Integrated Freewheel FXM is centered via the outer track F on the customer attachment part and bolted to this (refer to figure 63-1). The tolerance of the pilot diameter of the attachment part must be ISO h6 or h7.

The tolerance of the shaft must be ISO h6 or j6.

For fitting to shaft ends, end covers can be supplied upon request (refer to figure 63-3).

Integrated Freewheels FXM ... DX and FXM ... SX

for bolting to the face
with sprag lift-off X

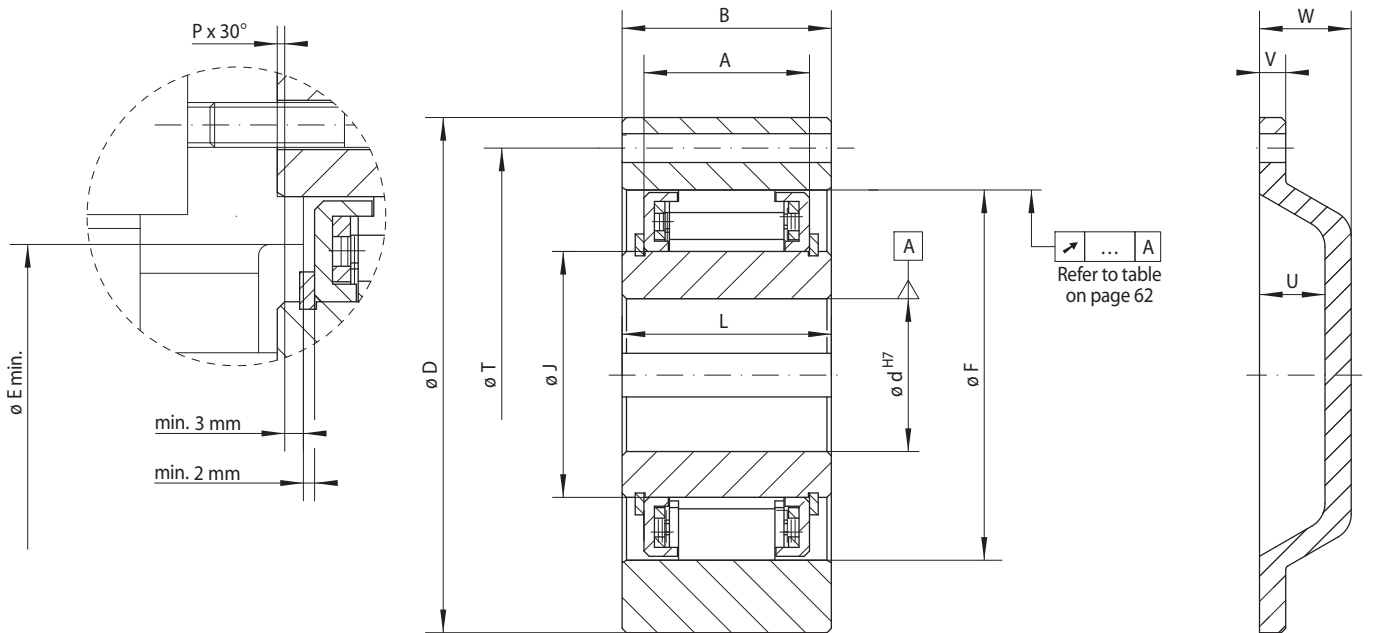

63-1

63-2

63-3

Freewheel Size	Bore d							A	B	D	E min.	F	G	J	L	P	T	U	V	W	Z**	Weight kg
	mm	mm	mm	mm	mm	mm	max. mm															
FXM 31 -17	20*						20*	17	25	85	41	55	M6	31	24	1,0	70	15	6	21	6	0,8
FXM 38 -17	25*						25*	17	25	90	48	62	M6	38	24	1,0	75	15	6	21	6	0,9
FXM 46 -25	25						30	25	35	95	56	70	M6	46	35	1,0	82	15	6	21	6	1,3
FXM 51 -25	25	30	35				36	25	35	105	62	75	M6	51	35	1,0	90	15	6	21	6	1,7
FXM 56 -25	35						40	25	35	110	66	80	M6	56	35	1,0	96	15	6	21	8	1,8
FXM 61 -19	30	35	40				45*	19	27	120	74	85	M8	61	25	1,0	105	15	6	21	6	1,8
FXM 66 -25	35	40	45				48*	25	35	132	82	90	M8	66	35	1,0	115	15	8	23	8	2,8
FXM 76 -25	45	55					60*	25	35	140	92	100	M8	76	35	1,0	125	15	8	23	8	3,1
FXM 86 -25	40	45	50	60	65		70*	25	40	150	102	110	M8	86	40	1,0	132	15	8	23	8	4,2
FXM 101 -25	55	70					80*	25	50	175	117	125	M10	101	50	1,0	155	20	8	28	8	6,9
FXM 85 -40	45	50	60	65			65	40	50	175	102	125	M10	85	60	1,0	155	20	8	28	8	7,4
FXM 100 -40	45	50	55	60	70	75	80*	40	50	190	130	140	M10	100	60	1,5	165	25	10	35	12	8,8
FXM 120 -50	60	65	70	75	80	95	95	50	60	210	150	160	M10	120	70	1,5	185	25	10	35	12	12,7
FXM 140 -50	65	90	100	110			110	50	70	245	170	180	M12	140	70	2,0	218	25	12	35	12	19,8
FXM 170 -63	70	85	90	100	120		130	63	80	290	200	210	M16	170	80	2,0	258	28	12	38	12	33,0
FXM 200 -63	130						155	63	80	310	230	240	M16	200	80	2,0	278	32	12	42	12	32,0

Keyway according to DIN 6885, page 1 • Tolerance of keyway width JS10.

* Keyway according to DIN 6885, page 3 • Tolerance of keyway width JS10.

** Z = Number of fastening holes for screws G on pitch circle T.

Lubrication

At speeds in excess of the sprag lift-off speed, no special lubrication is required; the freewheel functions maintenance-free.

When operating below the sprag lift-off speed, an oil lubrication of the specified oil quality must be provided.

Example for ordering

Freewheel size FXM 140 – 50, type with sprag lift-off X and 100 mm bore and end cover:

- FXM 140 - 50 SX, d = 100 mm, with end cover

Integrated Freewheels FXM ... UX

for bolting to the face
with sprag lift-off X

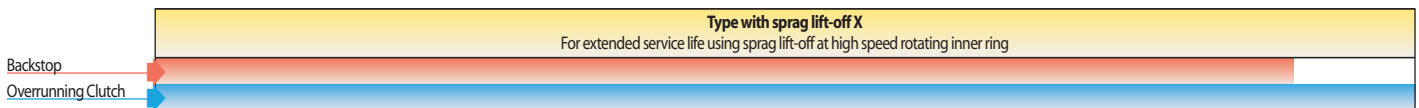
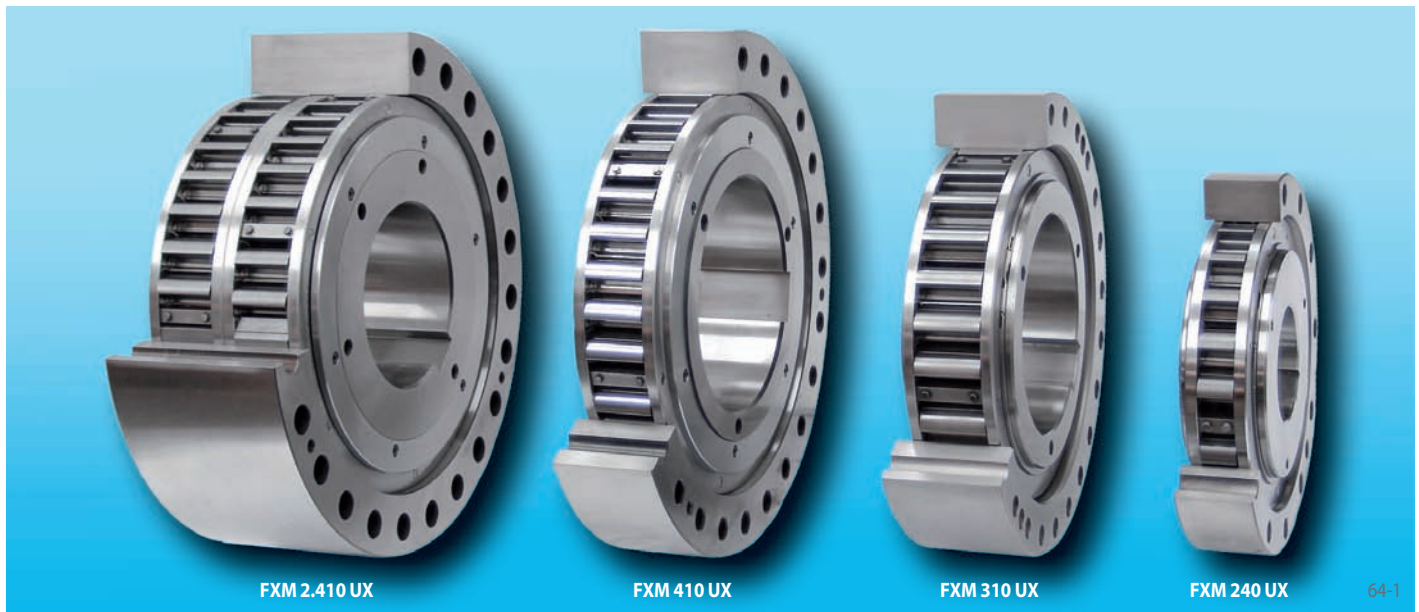

Freewheel Size	Type	Theoretical nominal torque		Nominal torque at existing run out (T.I.R.)						Sprag lift-off at inner ring speed min ⁻¹	Max. speed	
		0 A Nm	0,1 A Nm	0,2 A Nm	0,3 A Nm	0,4 A Nm	0,5 A Nm	0,8 A Nm	Inner ring freewheels/overruns min ⁻¹		Outer ring drives min ⁻¹	
FXM 240 -63 UX	UX	31 000	30 500	30 000	29 000	26 000	24 000	19 500	220	3 000	88	
FXM 240 -96 UX	UX	52 050	51 000	49 000	47 500	46 000	44 000	35 000	220	2 500	88	
FXM 2.240 -70 UX	UX	68 500	67 500	67 500	65 500	62 500	57 000	49 500	220	2 500	88	
FXM 2.240 -96 UX	UX	102 500	100 500	100 000	99 500	92 500	88 500	75 000	220	2 500	88	
FXM 260 -63 UX	UX	38 500	38 000	37 000	36 500	33 000	29 000	25 000	210	2 250	84	
FXM 290 -70 UX	UX	59 500	59 000	56 000	50 000	47 000	45 000	37 000	200	2 250	80	
FXM 290 -96 UX	UX	91 000	90 000	82 500	77 500	70 000	62 500	55 000	200	2 250	80	
FXM 2.290 -70 UX	UX	110 000	109 000	107 000	106 500	96 500	85 000	73 500	200	2 250	80	
FXM 2.290 -96 UX	UX	166 500	165 000	162 500	160 000	143 500	126 500	111 500	200	2 250	80	
FXM 310 -70 UX	UX	69 000	68 000	64 500	60 000	55 000	49 000	43 000	195	2 250	78	
FXM 310 -96 UX	UX	107 000	105 000	99 000	85 500	81 000	74 000	68 000	195	2 100	78	
FXM 320 -70 UX	UX	76 500	73 000	67 000	62 000	56 500	49 500	43 000	195	2 000	78	
FXM 320 -96 UX	UX	110 500	105 500	104 500	92 500	83 500	73 500	67 000	195	2 000	78	
FXM 2.320 -70 UX	UX	143 500	142 000	138 000	122 500	112 000	97 500	87 000	195	2 000	78	
FXM 2.320 -96 UX	UX	208 500	206 000	205 000	190 500	171 500	151 000	133 000	195	2 000	78	
FXM 360 -100 UX	UX	149 000	139 500	128 000	119 500	103 500	90 000	80 500	180	1 800	72	
FXM 2.360 -73 UX	UX	194 500	188 000	165 500	154 000	141 000	125 500	108 500	180	1 800	72	
FXM 2.360 -100 UX	UX	278 500	275 500	265 500	242 000	219 000	188 000	171 500	180	1 800	72	
FXM 410 -100 UX	UX	193 000	179 500	167 000	154 500	137 000	121 500	111 500	170	1 500	68	
FXM 2.410 -73 UX	UX	245 000	243 000	221 500	201 500	184 500	159 500	142 000	170	1 500	68	
FXM 2.410 -100 UX	UX	386 000	359 000	334 000	309 000	274 000	243 000	223 000	170	1 500	68	

The maximum transmissible torque is 2 times the specified nominal torque. See page 14 for determination of selection torque.
The theoretical nominal torque applies only for ideal concentricity between the inner and outer ring. In practice, the concentricity is affected by the bearing play and centering errors of the neighbouring parts. Then the nominal torques specified in the table apply, whilst taking into consideration the existing run out (T.I.R.).
Higher speeds upon request.

Mounting

Integrated Freewheels FXM are without bearing support. Concentric alignment of inner and outer ring must be provided by the customer. The permissible run out (T.I.R.) must be observed.

The Integrated Freewheel FXM is centered via the outer track F on the customer attachment part and bolted to this (refer to figure 65-1). The tolerance of the pilot diameter of the attachment part must be ISO h6 or h7.

The tolerance of the shaft must be ISO h6 or j6.

Integrated Freewheels FXM ... UX

for bolting to the face
with sprag lift-off X

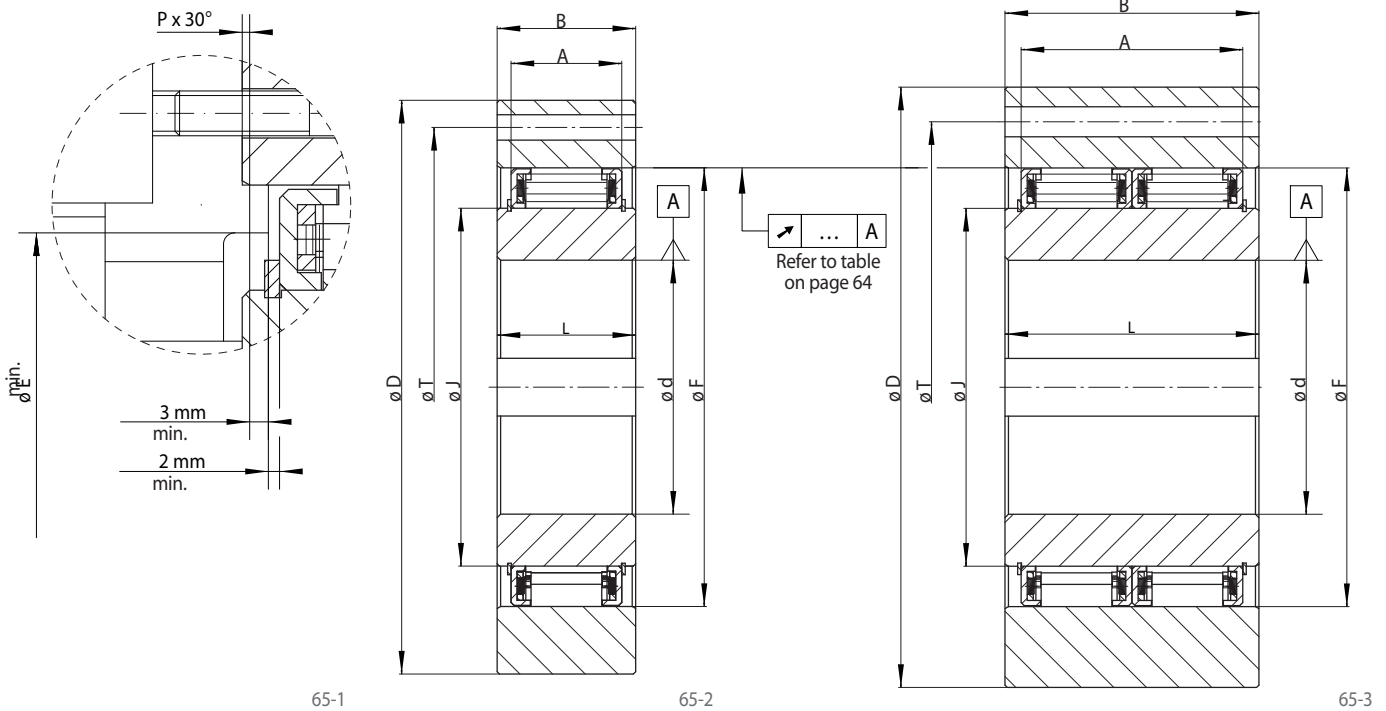

Freewheel Size	Bore d max. mm	A mm	B mm	D mm	E min. mm	F mm	G	J mm	L mm	P mm	T mm	Z**	Weight kg
FXM 240 - 63	185	63	80	400	280	310	M20	240	90	2,0	360	12	60
FXM 240 - 96	185	96	125	420	280	310	M24	240	120	2,0	370	16	95
FXM 2.240 - 70	185	140	160	412	280	310	M20	240	160	2,0	360	24	120
FXM 2.240 - 96	185	192	240	425	280	310	M24	240	240	2,0	370	24	200
FXM 260 - 63	205	63	80	430	300	330	M20	260	105	2,0	380	16	75
FXM 290 - 70	230	70	80	460	330	360	M20	290	105	2,0	410	16	90
FXM 290 - 96	230	96	110	460	330	360	M20	290	120	2,0	410	16	91
FXM 2.290 - 70	230	140	160	480	330	360	M24	290	160	2,0	410	18	170
FXM 2.290 - 96	230	192	240	490	330	360	M30	290	240	2,0	425	20	260
FXM 310 - 70	240	70	125	497	360	380	M20	310	110	3,0	450	24	135
FXM 310 - 96	240	96	125	497	360	380	M20	310	120	3,0	450	24	145
FXM 320 - 70	250	70	80	490	360	390	M24	320	105	3,0	440	16	105
FXM 320 - 96	250	96	120	520	360	390	M24	320	120	3,0	440	16	150
FXM 2.320 - 70	250	140	180	505	360	390	M24	320	180	3,0	440	24	200
FXM 2.320 - 96	250	192	240	530	360	390	M30	320	240	3,0	460	24	310
FXM 360 - 100	280	100	120	540	400	430	M24	360	125	3,0	500	24	170
FXM 2.360 - 73	280	146	210	550	400	430	M24	360	210	3,0	500	24	270
FXM 2.360 - 100	280	200	250	580	400	430	M30	360	250	3,0	500	24	380
FXM 410 - 100	320	100	120	630	460	480	M24	410	125	3,0	560	24	245
FXM 2.410 - 73	320	146	210	630	460	460	M24	410	210	3,0	560	24	400
FXM 2.410 - 100	320	200	220	630	460	480	M30	410	220	3,0	560	24	440

Keyway according to DIN 6885, page 1 • Tolerance of keyway width JS10.

* Keyway according to DIN 6885, page 3 • Tolerance of keyway width JS10.

** Z = Number of fastening holes for screws G on pitch circle T.

Lubrication

At speeds in excess of the sprag lift-off speed, no special lubrication is required; the freewheel functions maintenance-free.

When operating below the sprag lift-off speed, an oil lubrication of the specified oil quality must be provided.

Example for ordering

Freewheel size FXM 240 – 63, type with sprag lift-off X and 140 mm bore:

- FXM 240 - 63 UX, d = 140 mm